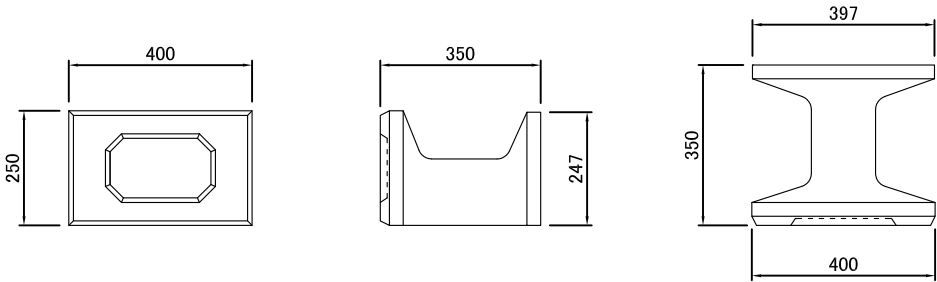
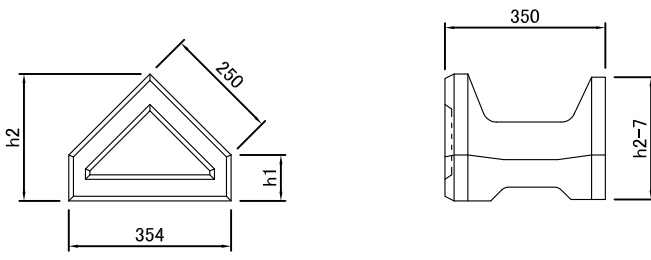
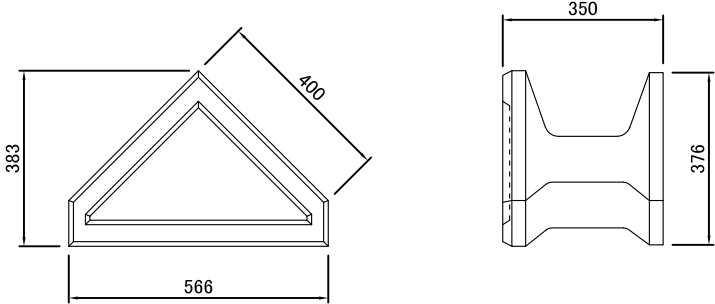
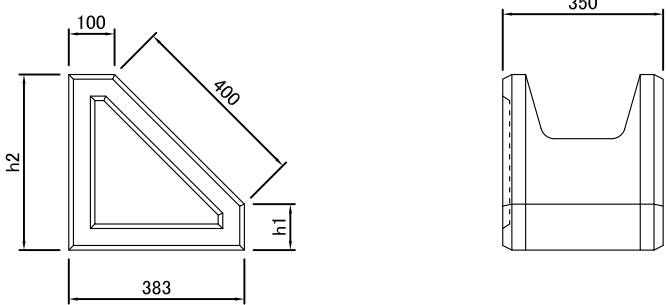
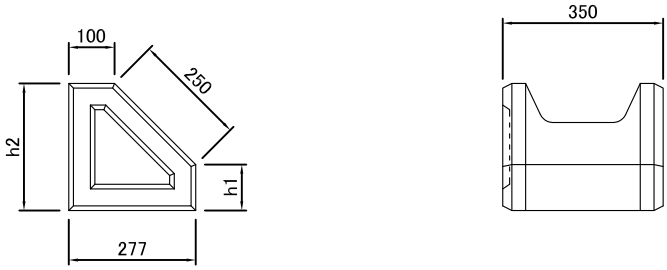
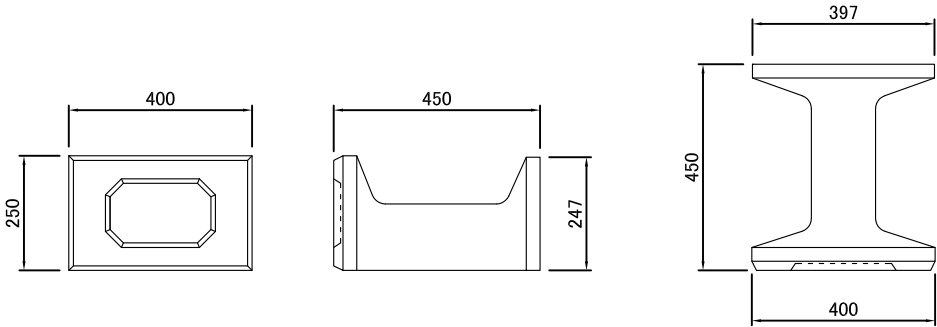
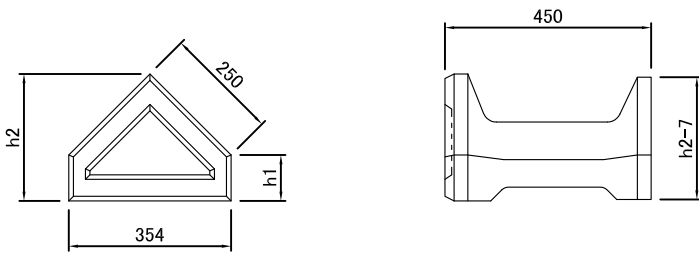
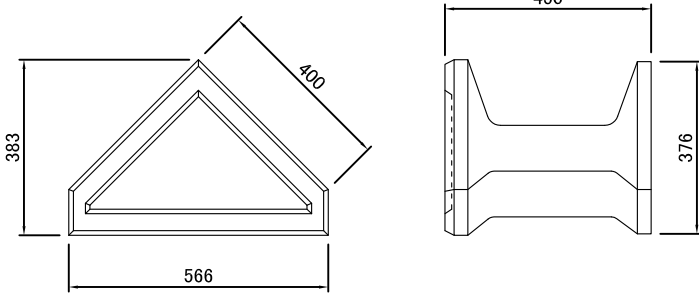
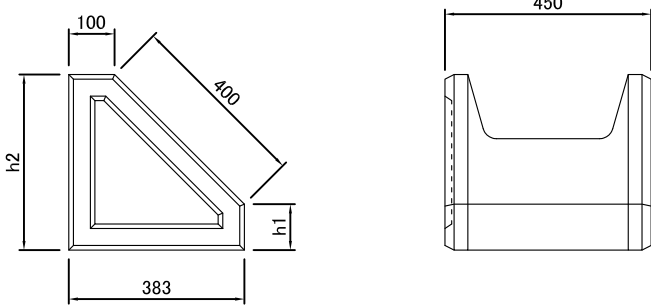
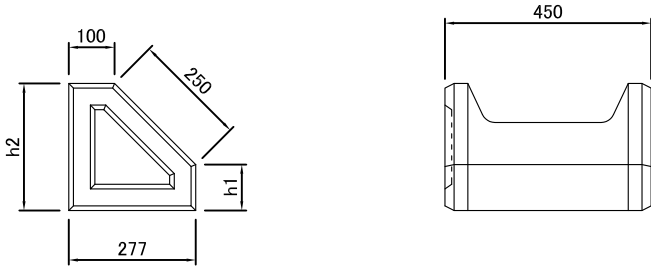

間知ブロック 控350

<p>並 型</p>	 <p>参考重量 35kg</p>																		
<p>異 型</p>	 <table border="1" data-bbox="1165 672 1404 862"> <thead> <tr> <th rowspan="2">呼び名</th> <th colspan="2">寸法 (mm)</th> <th rowspan="2">参考重量 (kg)</th> </tr> <tr> <th>h1</th> <th>h2</th> </tr> </thead> <tbody> <tr> <td>H50</td> <td>50</td> <td>227</td> <td>18</td> </tr> <tr> <td>H100</td> <td>100</td> <td>277</td> <td>25</td> </tr> <tr> <td>H150</td> <td>150</td> <td>327</td> <td>30</td> </tr> </tbody> </table>	呼び名	寸法 (mm)		参考重量 (kg)	h1	h2	H50	50	227	18	H100	100	277	25	H150	150	327	30
呼び名	寸法 (mm)		参考重量 (kg)																
	h1	h2																	
H50	50	227	18																
H100	100	277	25																
H150	150	327	30																
<p>袖 石</p>	 <p>参考重量 50kg</p>																		
<p>角 石 (大)</p>	 <table border="1" data-bbox="1165 1489 1404 1680"> <thead> <tr> <th rowspan="2">呼び名</th> <th colspan="2">寸法 (mm)</th> <th rowspan="2">参考重量 (kg)</th> </tr> <tr> <th>h1</th> <th>h2</th> </tr> </thead> <tbody> <tr> <td>H50</td> <td>50</td> <td>333</td> <td>39</td> </tr> <tr> <td>H100</td> <td>100</td> <td>383</td> <td>47</td> </tr> <tr> <td>H150</td> <td>150</td> <td>433</td> <td>58</td> </tr> </tbody> </table>	呼び名	寸法 (mm)		参考重量 (kg)	h1	h2	H50	50	333	39	H100	100	383	47	H150	150	433	58
呼び名	寸法 (mm)		参考重量 (kg)																
	h1	h2																	
H50	50	333	39																
H100	100	383	47																
H150	150	433	58																
<p>角 石 (小)</p>	 <table border="1" data-bbox="1165 1881 1404 2072"> <thead> <tr> <th rowspan="2">呼び名</th> <th colspan="2">寸法 (mm)</th> <th rowspan="2">参考重量 (kg)</th> </tr> <tr> <th>h1</th> <th>h2</th> </tr> </thead> <tbody> <tr> <td>H50</td> <td>50</td> <td>227</td> <td>22</td> </tr> <tr> <td>H100</td> <td>100</td> <td>277</td> <td>28</td> </tr> <tr> <td>H150</td> <td>150</td> <td>327</td> <td>35</td> </tr> </tbody> </table>	呼び名	寸法 (mm)		参考重量 (kg)	h1	h2	H50	50	227	22	H100	100	277	28	H150	150	327	35
呼び名	寸法 (mm)		参考重量 (kg)																
	h1	h2																	
H50	50	227	22																
H100	100	277	28																
H150	150	327	35																

間知ブロック 控450

<p>並 型</p>	 <p>参考重量 43kg</p>																		
<p>異 型</p>	 <table border="1" data-bbox="1165 672 1404 862"> <thead> <tr> <th rowspan="2">呼び名</th> <th colspan="2">寸法 (mm)</th> <th rowspan="2">参考重量 (kg)</th> </tr> <tr> <th>h1</th> <th>h2</th> </tr> </thead> <tbody> <tr> <td>H50</td> <td>50</td> <td>227</td> <td>27</td> </tr> <tr> <td>H100</td> <td>100</td> <td>277</td> <td>34</td> </tr> <tr> <td>H150</td> <td>150</td> <td>327</td> <td>38</td> </tr> </tbody> </table>	呼び名	寸法 (mm)		参考重量 (kg)	h1	h2	H50	50	227	27	H100	100	277	34	H150	150	327	38
呼び名	寸法 (mm)		参考重量 (kg)																
	h1	h2																	
H50	50	227	27																
H100	100	277	34																
H150	150	327	38																
<p>袖 石</p>	 <p>参考重量 67kg</p>																		
<p>角 石 (大)</p>	 <table border="1" data-bbox="1165 1489 1404 1680"> <thead> <tr> <th rowspan="2">呼び名</th> <th colspan="2">寸法 (mm)</th> <th rowspan="2">参考重量 (kg)</th> </tr> <tr> <th>h1</th> <th>h2</th> </tr> </thead> <tbody> <tr> <td>H50</td> <td>50</td> <td>333</td> <td>46</td> </tr> <tr> <td>H100</td> <td>100</td> <td>383</td> <td>55</td> </tr> <tr> <td>H150</td> <td>150</td> <td>433</td> <td>65</td> </tr> </tbody> </table>	呼び名	寸法 (mm)		参考重量 (kg)	h1	h2	H50	50	333	46	H100	100	383	55	H150	150	433	65
呼び名	寸法 (mm)		参考重量 (kg)																
	h1	h2																	
H50	50	333	46																
H100	100	383	55																
H150	150	433	65																
<p>角 石 (小)</p>	 <table border="1" data-bbox="1165 1881 1404 2072"> <thead> <tr> <th rowspan="2">呼び名</th> <th colspan="2">寸法 (mm)</th> <th rowspan="2">参考重量 (kg)</th> </tr> <tr> <th>h1</th> <th>h2</th> </tr> </thead> <tbody> <tr> <td>H50</td> <td>50</td> <td>227</td> <td>29</td> </tr> <tr> <td>H100</td> <td>100</td> <td>277</td> <td>32</td> </tr> <tr> <td>H150</td> <td>150</td> <td>327</td> <td>45</td> </tr> </tbody> </table>	呼び名	寸法 (mm)		参考重量 (kg)	h1	h2	H50	50	227	29	H100	100	277	32	H150	150	327	45
呼び名	寸法 (mm)		参考重量 (kg)																
	h1	h2																	
H50	50	227	29																
H100	100	277	32																
H150	150	327	45																

間知ブロック 控500

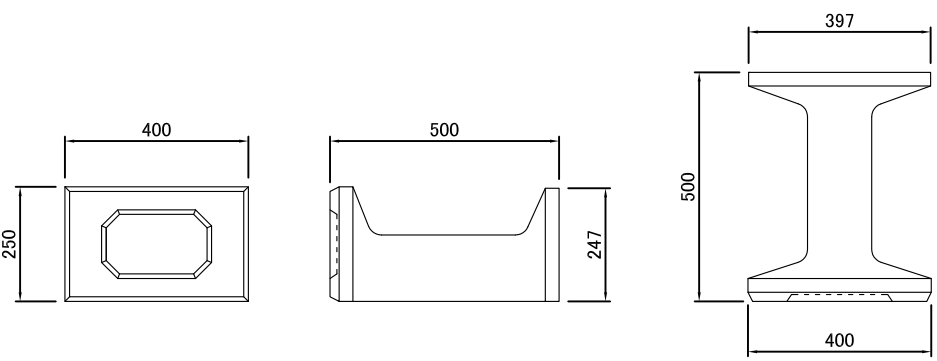
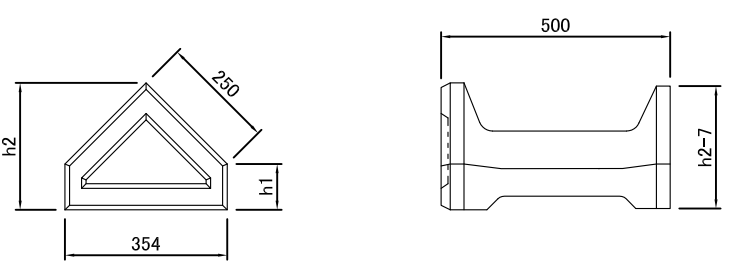
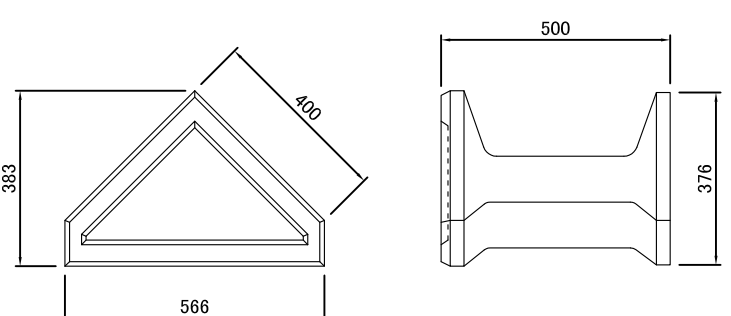
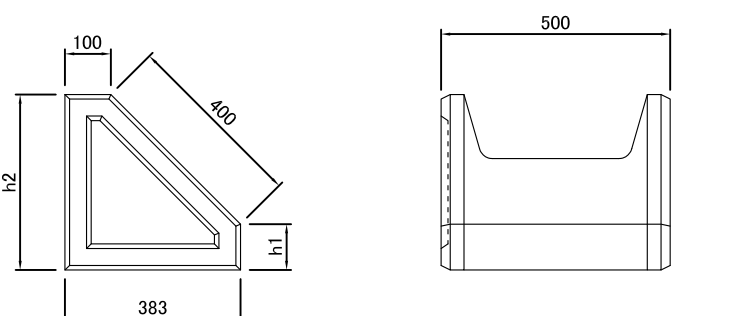
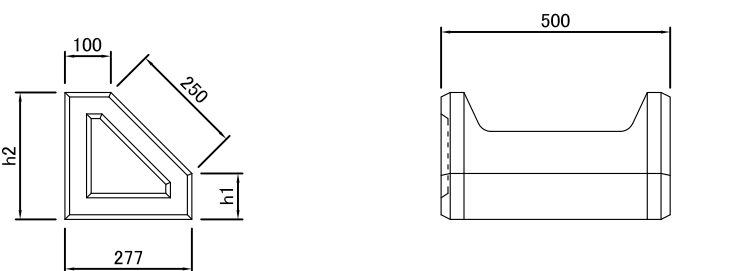
<p>並 型</p>	 <p>参考重量 47kg</p>																		
<p>異 型</p>	 <table border="1" data-bbox="1133 649 1372 840"> <thead> <tr> <th rowspan="2">呼び名</th> <th colspan="2">寸法 (mm)</th> <th rowspan="2">参考重量 (kg)</th> </tr> <tr> <th>h1</th> <th>h2</th> </tr> </thead> <tbody> <tr> <td>H50</td> <td>50</td> <td>227</td> <td>32</td> </tr> <tr> <td>H100</td> <td>100</td> <td>277</td> <td>39</td> </tr> <tr> <td>H150</td> <td>150</td> <td>327</td> <td>42</td> </tr> </tbody> </table>	呼び名	寸法 (mm)		参考重量 (kg)	h1	h2	H50	50	227	32	H100	100	277	39	H150	150	327	42
呼び名	寸法 (mm)		参考重量 (kg)																
	h1	h2																	
H50	50	227	32																
H100	100	277	39																
H150	150	327	42																
<p>袖 石</p>	 <p>参考重量 76kg</p>																		
<p>角 石 (大)</p>	 <table border="1" data-bbox="1133 1467 1372 1657"> <thead> <tr> <th rowspan="2">呼び名</th> <th colspan="2">寸法 (mm)</th> <th rowspan="2">参考重量 (kg)</th> </tr> <tr> <th>h1</th> <th>h2</th> </tr> </thead> <tbody> <tr> <td>H50</td> <td>50</td> <td>333</td> <td>50</td> </tr> <tr> <td>H100</td> <td>100</td> <td>383</td> <td>59</td> </tr> <tr> <td>H150</td> <td>150</td> <td>433</td> <td>69</td> </tr> </tbody> </table>	呼び名	寸法 (mm)		参考重量 (kg)	h1	h2	H50	50	333	50	H100	100	383	59	H150	150	433	69
呼び名	寸法 (mm)		参考重量 (kg)																
	h1	h2																	
H50	50	333	50																
H100	100	383	59																
H150	150	433	69																
<p>角 石 (小)</p>	 <table border="1" data-bbox="1133 1859 1372 2049"> <thead> <tr> <th rowspan="2">呼び名</th> <th colspan="2">寸法 (mm)</th> <th rowspan="2">参考重量 (kg)</th> </tr> <tr> <th>h1</th> <th>h2</th> </tr> </thead> <tbody> <tr> <td>H50</td> <td>50</td> <td>227</td> <td>33</td> </tr> <tr> <td>H100</td> <td>100</td> <td>277</td> <td>34</td> </tr> <tr> <td>H150</td> <td>150</td> <td>327</td> <td>50</td> </tr> </tbody> </table>	呼び名	寸法 (mm)		参考重量 (kg)	h1	h2	H50	50	227	33	H100	100	277	34	H150	150	327	50
呼び名	寸法 (mm)		参考重量 (kg)																
	h1	h2																	
H50	50	227	33																
H100	100	277	34																
H150	150	327	50																

基礎ブロック

積ブロック控長35cm用(3分勾配用)
5分勾配用)

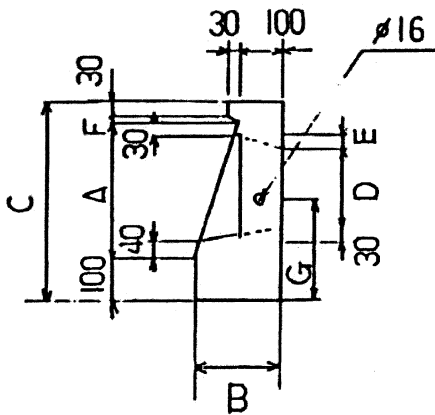
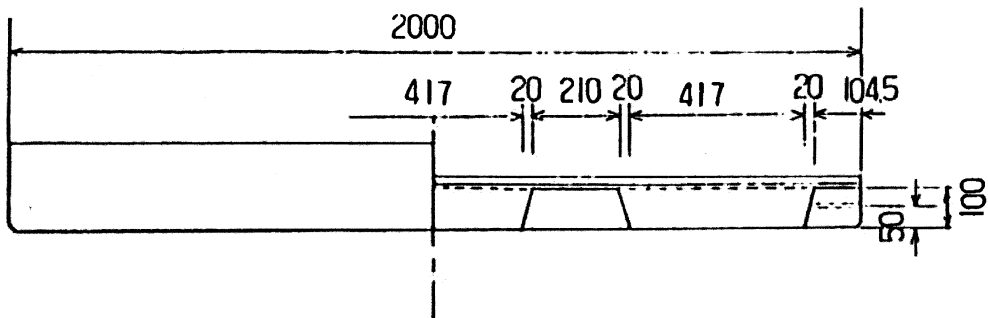
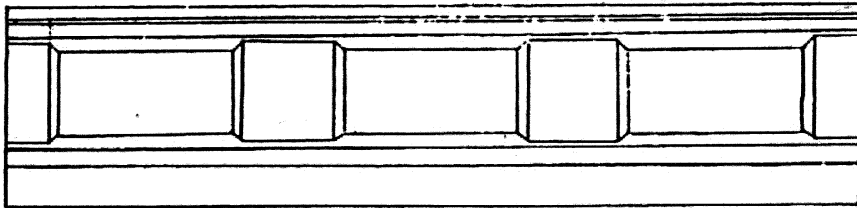

	3分用350	5分用350
A	340	318
B	202	259
C	479	463
D	207.3	160.5
E	32.7	57.5
F	9	15
G	240	230

参考重量 現場打コンクリート

3分用 256.5kg 0.09m³

5分用 269.2kg 0.08m³

ℓ=1.0mも製作致します。

基礎ブロック

積みブロック控長50cm用(5分勾配)

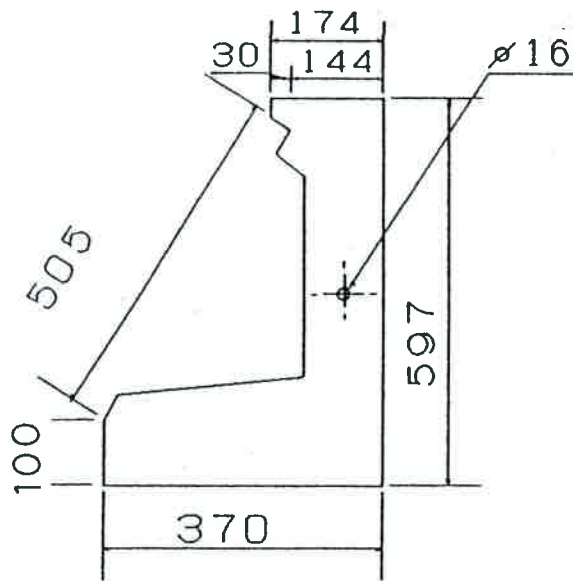
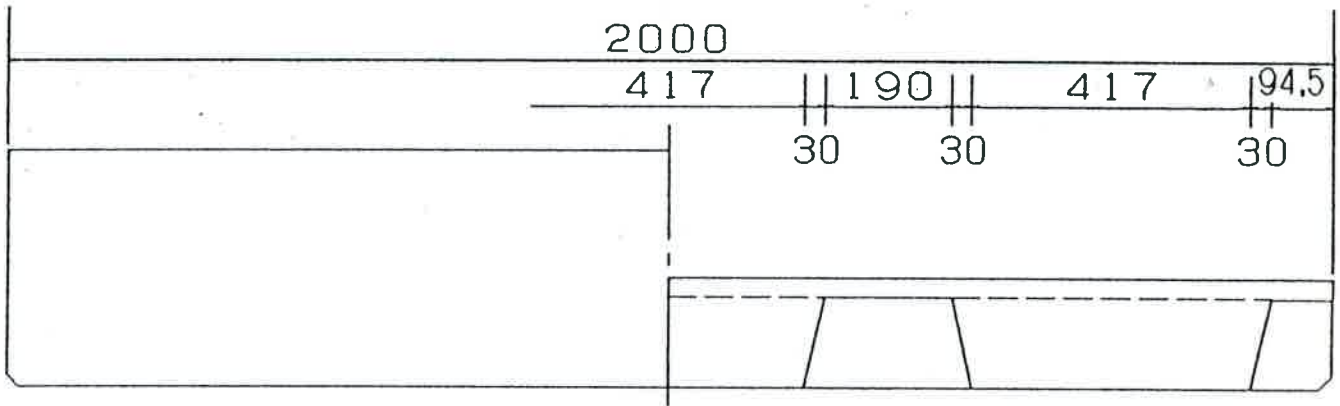
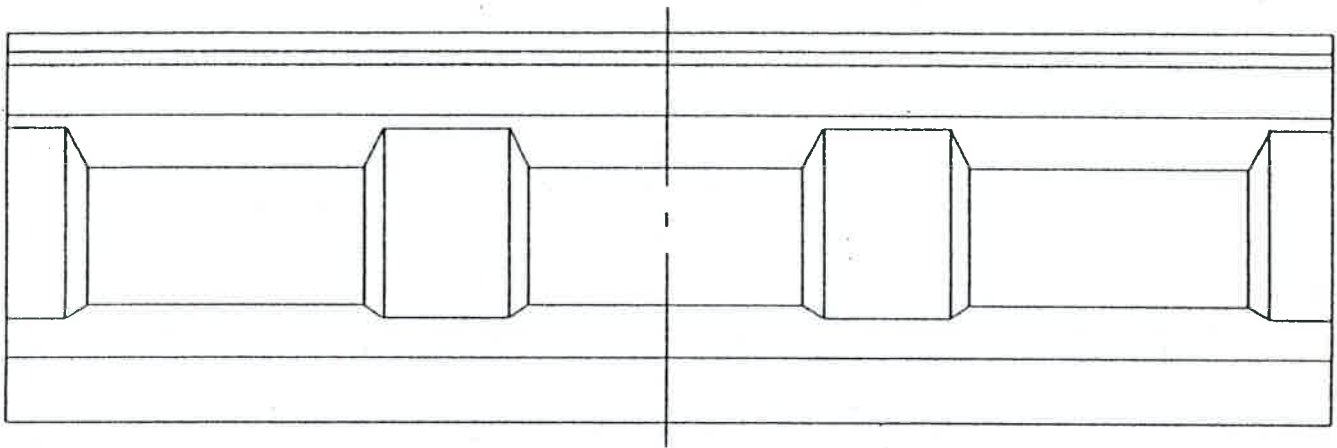

参考重量

460kg

胴込量

0.13m³/2m